

EN2042102 วงจรไฟฟ้าและอิเล็กทรอนิกส์

Circuits and Electronics



บทที่ 1 พื้นฐานทางไฟฟ้า



สาขาวิชาวิศวกรรมคอมพิวเตอร์

คณะวิศวกรรมศาสตร์ มหาวิทยาลัยเทคโนโลยีราชมงคลพระนคร



วัตถุประสงค์ (OBJECTIVES)

- ❖ บอกวัดทางไฟฟ้า และหน่วยวัดทางปริมาณที่ใช้ในทางไฟฟ้า
- ❖ บอกชนิดของตัวต้านทานประเภทต่าง ๆ ได้
- ❖ คำนวณวงจรพื้นฐานทางไฟฟ้าอย่างง่ายได้ (อนุกรม, ขนาน, ผสม)





พื้นฐานทางไฟฟ้า



FIXED-POINT, FLOATING-POINT, SCIENTIFIC, AND ENGINEERING NOTATION

Prefixes



Multiplication Factors	SI Prefix	SI Symbol
1 000 000 000 000 000 000 = 10^{18}	exa	E
1 000 000 000 000 000 = 10^{15}	peta	P
1 000 000 000 000 = 10^{12}	tera	T
1 000 000 000 = 10^9	giga	G
1 000 000 = 10^6	mega	M
1 000 = 10^3	kilo	k
0.001 = 10^{-3}	milli	m
0.000 001 = 10^{-6}	micro	μ
0.000 000 001 = 10^{-9}	nano	n
0.000 000 000 001 = 10^{-12}	pico	p
0.000 000 000 000 001 = 10^{-15}	femto	f
0.000 000 000 000 000 001 = 10^{-18}	atto	a

TABLE 1.2



แรงดันไฟฟ้า และกระแสไฟฟ้า



INTRODUCTION



- ❖ Now that the foundation for the study of electricity/electronics has been established, the concepts of voltage and current can be investigated.
 - The term **voltage** is encountered practically every day.
 - We are aware that most outlets in our homes are 220 volts.
- ❖ Although **current** may be a less familiar term, we know what happens when we place too many appliances on the same outlet—the circuit breaker opens due to the excessive current that results.



VOLTAGE



❖ Since it would be inconsequential to talk about the voltage established by the separation of a single electron, a package of electrons called a **coulomb (C)** of charge was defined as follows:

- *One coulomb of charge is the total charge associated with 6.242×10^{18} electrons.*
- *If a total of 1 joule (J) of energy is used to move the negative charge of 1 coulomb (C), there is a difference of 1 volt (V) between the two points.*



VOLTAGE



❖ Since the **potential energy** associated with a body is defined by its position, the term *potential* is often applied to define voltage levels.

- For example, the difference in potential is 4 V between the two points, or the **potential difference** between a point and ground is 12 V, and so on.



CURRENT

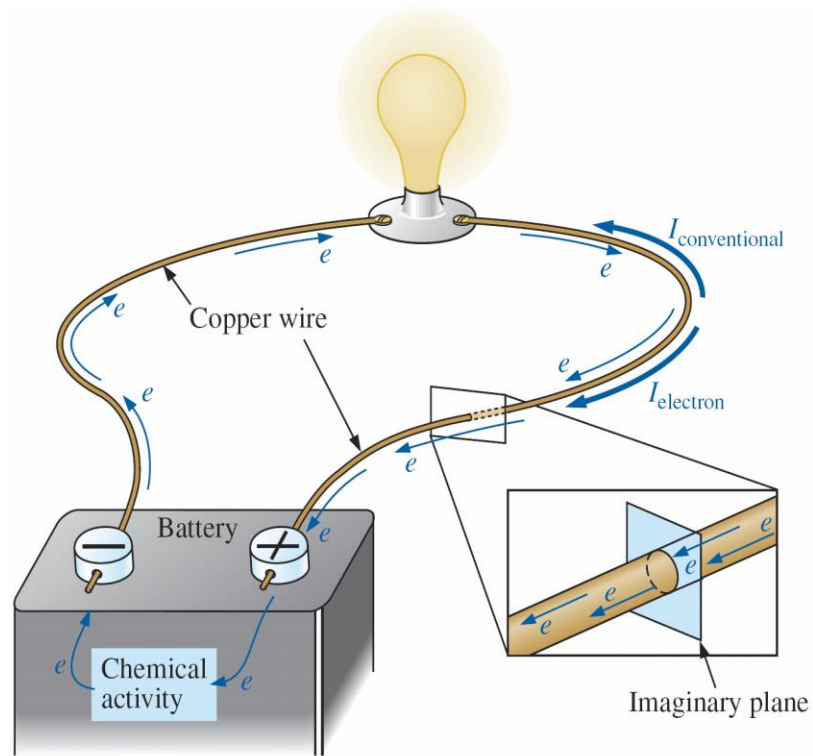

FIG. 2.9 *Basic electric circuit.*





CURRENT



- ❖ The unit of current measurement, **ampere**, was chosen to honor the efforts of André Ampère in the study of electricity in motion.
- ❖ In summary, therefore, *the applied voltage (or potential difference) in an electrical/electronics system is the “pressure” to set the system in motion, and the current is the reaction to that pressure.*



VOLTAGE SOURCES

❖ The term **dc**, used throughout this text, is an abbreviation for **direct current**, which encompasses all systems where there is a unidirectional (one direction) flow of charge.

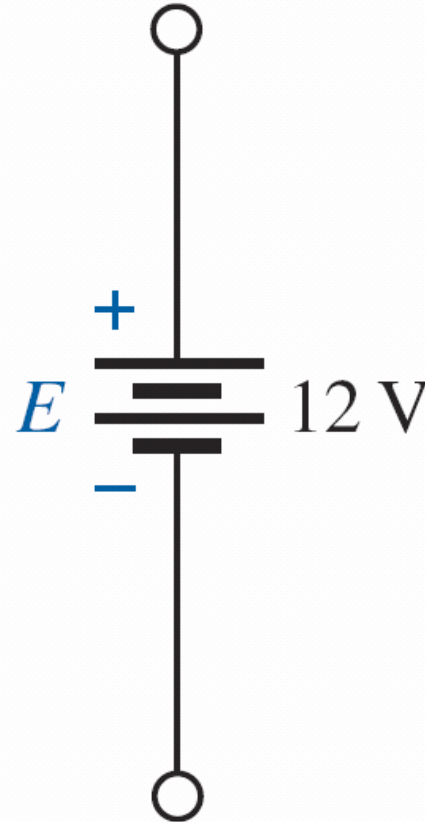

FIG. 2.11 *Standard symbol for a dc voltage source.*





VOLTAGE SOURCES



❖ In general, dc voltage sources can be divided into three basic types:

- Batteries (chemical action or solar energy)
- Generators (electromechanical), and
- Power supplies (rectification—a conversion process to be described in your electronics courses).



VOLTAGE SOURCES

Batteries

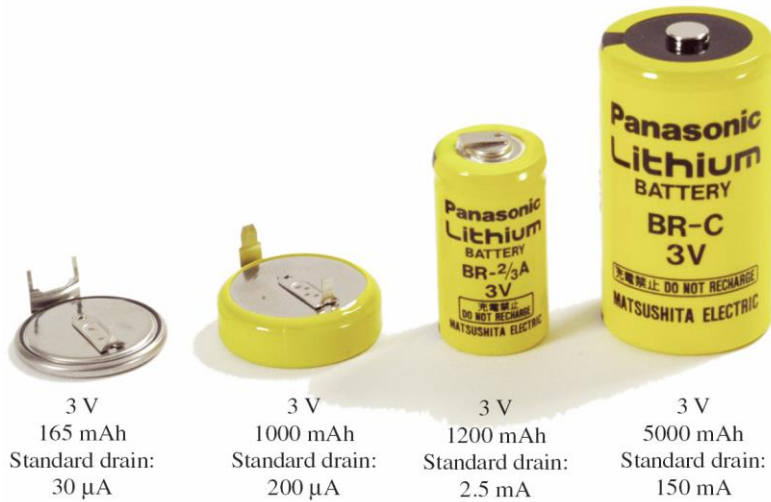

FIG. 2.13 *Lithium primary batteries.*



FIG. 2.16 *Dell laptop lithium-ion battery: 11.1 V, 4400 mAh.*



VOLTAGE SOURCES

Solar Cell



FIG. 2.17 Solar System: (a) panels on roof of garage; (b) system operation.

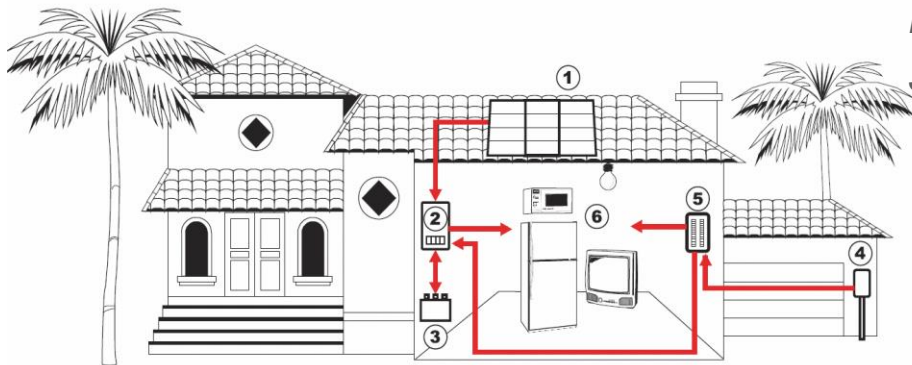



VOLTAGE SOURCES

Generators

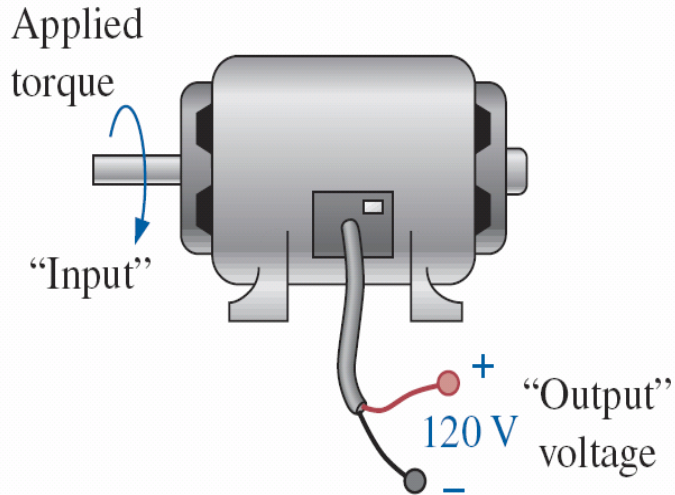

FIG. 2.18
dc generator.



FIG. 2.19 *A 0 V to 60 V, 0 to 1.5 A digital display dc power supply*





CONDUCTORS AND INSULATORS



- ❖ Different wires placed across the same two battery terminals allow different amounts of charge to flow between the terminals.
- ❖ Many factors, such as the density, mobility, and stability characteristics of a material, account for these variations in charge flow.
 - In general, however, *conductors are those materials that permit a generous flow of electrons with very little external force (voltage) applied.*
 - In addition, *good conductors typically have only one electron in the valence (most distant from the nucleus) ring.*



CONDUCTORS AND INSULATORS



Metal	Relative Conductivity (%)
Silver	105
Copper	100
Gold	70.5
Aluminum	61
Tungsten	31.2
Nickel	22.1
Iron	14
Constantan	3.52
Nichrome	1.73
Calorite	1.44

TABLE 2.1 *Relative conductivity of various materials*



CONDUCTORS AND INSULATORS

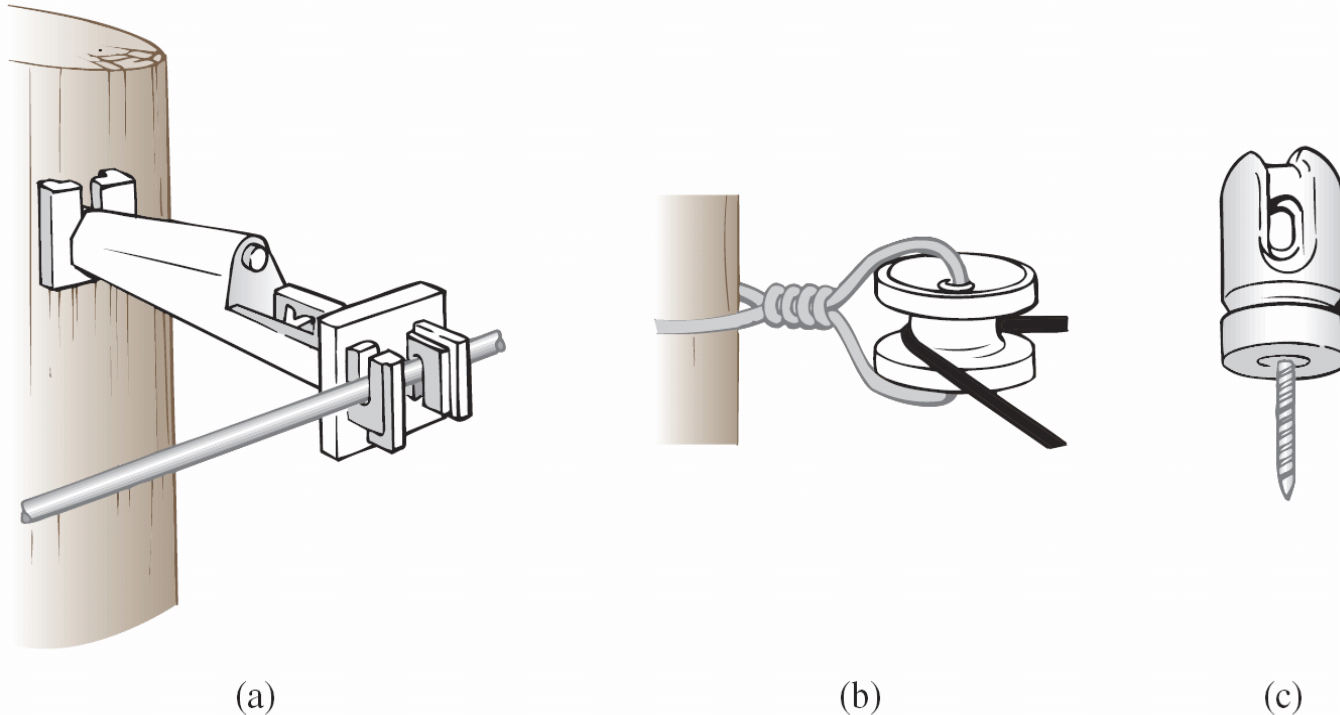

FIG. 2.26 Various types of insulators and their applications. (a) *Fi-Shock extender insulator*; (b) *Fi-Shock corner insulator*; (c) *Fi-Shock screw-in post insulator*.



CONDUCTORS AND INSULATORS



Material	Average Breakdown Strength (kV/cm)
Air	30
Porcelain	70
Oils	140
Bakelite®	150
Rubber	270
Paper (paraffin-coated)	500
Teflon®	600
Glass	900
Mica	2000

TABLE 2.2 Breakdown strength of some common insulators.



AMMETERS AND VOLTMETERS



- ❖ It is important to be able to measure the current and voltage levels of an operating electrical system to check its operation, isolate malfunctions, and investigate effects impossible to predict on paper.
- ❖ As the names imply, **ammeters** are used to measure current levels; **voltmeters**, the potential difference between two points.
- ❖ If the current levels are usually of the order of milliamperes, the instrument will typically be referred to as a *milliammeter*, and if the current levels are in the microampere range, as a *microammeter*.



AMMETERS AND VOLTMETERS

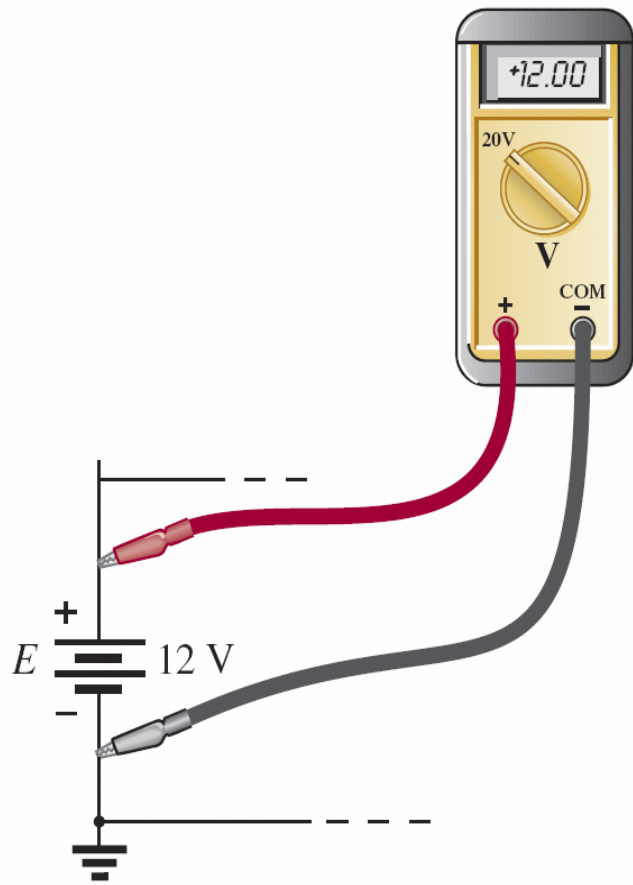

FIG. 2.27 *Voltmeter connection for an up-scale (+) reading.*



AMMETERS AND VOLTMETERS

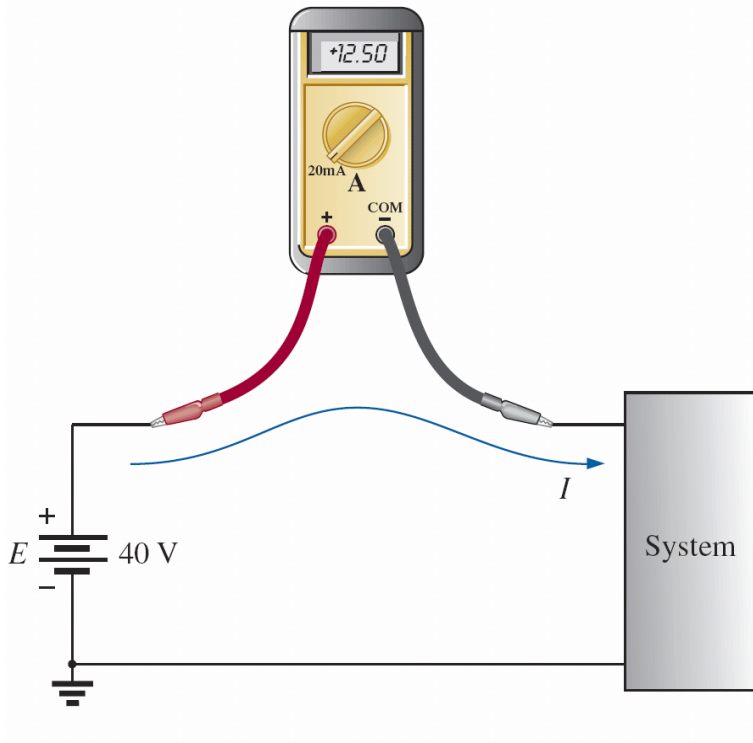

FIG. 2.28 *Ammeter connection for an up-scale (+) reading.*



AMMETERS AND VOLTMETERS



FIG. 2.29 Volt-ohm-milliammeter (VOM) analog meter.



FIG. 2.30 Digital multimeter (DMM).



ความต้านทาน

Resistance



INTRODUCTION

- ❖ This opposition to the flow of charge through an electrical circuit, called **resistance**, has the units of **ohms** and uses the Greek letter *omega* (Ω) as its symbol.
- ❖ The graphic symbol for resistance, which resembles the cutting edge of a saw.

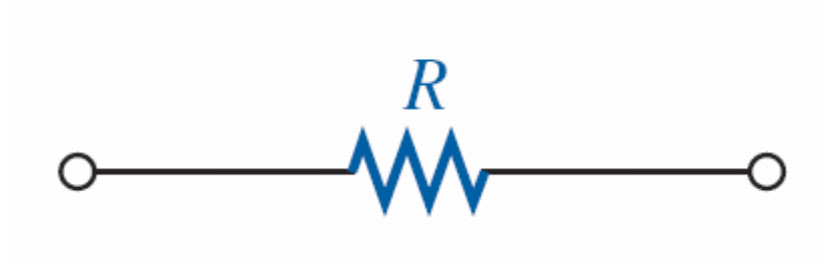

FIG. 3.1 Resistance symbol and notation.





RESISTANCE: CIRCULAR WIRES

❖ The resistance of any material is due primarily to four factors.

- *Material*
- *Length*
- *Cross-sectional area*
- *Temperature of the material*





RESISTANCE: CIRCULAR WIRES



- ❖ The first three elements are related by the following basic equation for resistance:

$$R = \rho \frac{l}{A}$$

$\rho = \text{CM-}\Omega/\text{ft}$ at $T = 20^\circ\text{C}$

$l = \text{feet}$

$A = \text{area in circular mils (CM)}$



RESISTANCE: CIRCULAR WIRES

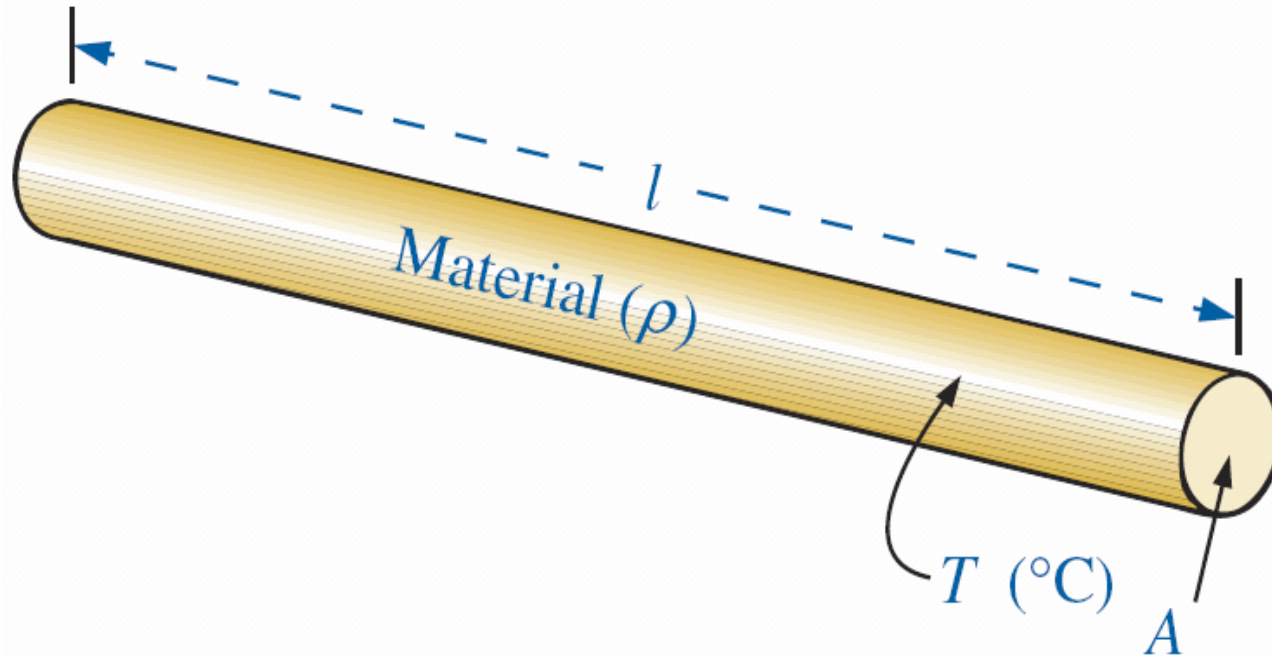

FIG. 3.2 Factors affecting the resistance of a conductor.



RESISTANCE: CIRCULAR WIRES



Material	ρ (CM- Ω /ft)@20°C
Silver	9.9
Copper	10.37
Gold	14.7
Aluminum	17.0
Tungsten	33.0
Nickel	47.0
Iron	74.0
Constantan	295.0
Nichrome	600.0
Calorite	720.0
Carbon	21,000.0

TABLE 3.1 Resistivity (ρ) of various materials.



WIRE TABLES



- ❖ The wire table was designed primarily to standardize the size of wire produced by manufacturers.
- ❖ As a result, the manufacturer has a larger market, and the consumer knows that standard wire sizes will always be available.
- ❖ The table was designed to assist the user in every way possible; it usually includes data such as the cross-sectional area in circular mils, diameter in mils, ohms per 1000 feet at 20°C, and weight per 1000 feet.



WIRE TABLES



AWG #	Area (CM)	Ω /1000 ft at 20°C	Maximum Allowable Current for RHW Insulation (A)*
(4/0)	0000	211,600	230
(3/0)	000	167,810	200
(2/0)	00	133,080	175
(1/0)	0	105,530	150
	1	83,694	130
	2	66,373	115
	3	52,634	100
	4	41,742	85
	5	33,102	—
	6	26,250	65
	7	20,816	—
	8	16,509	50
	9	13,094	—
	10	10,381	30
	11	8,234.0	—
	12	6,529.9	20
	13	5,178.4	—
	14	4,106.8	15
	15	3,256.7	
	16	2,582.9	
	17	2,048.2	
	18	1,624.3	
	19	1,288.1	
	20	1,021.5	
	21	810.10	
	22	642.40	
	23	509.45	
	24	404.01	
	25	320.40	
	26	254.10	
	27	201.50	
	28	159.79	
	29	126.72	
	30	100.50	
	31	79.70	
	32	63.21	
	33	50.13	
	34	39.75	
	35	31.52	
	36	25.00	
	37	19.83	
	38	15.72	
	39	12.47	
	40	9.89	

TABLE 3.2 American Wire Gage (AWG) sizes.



WIRE TABLES

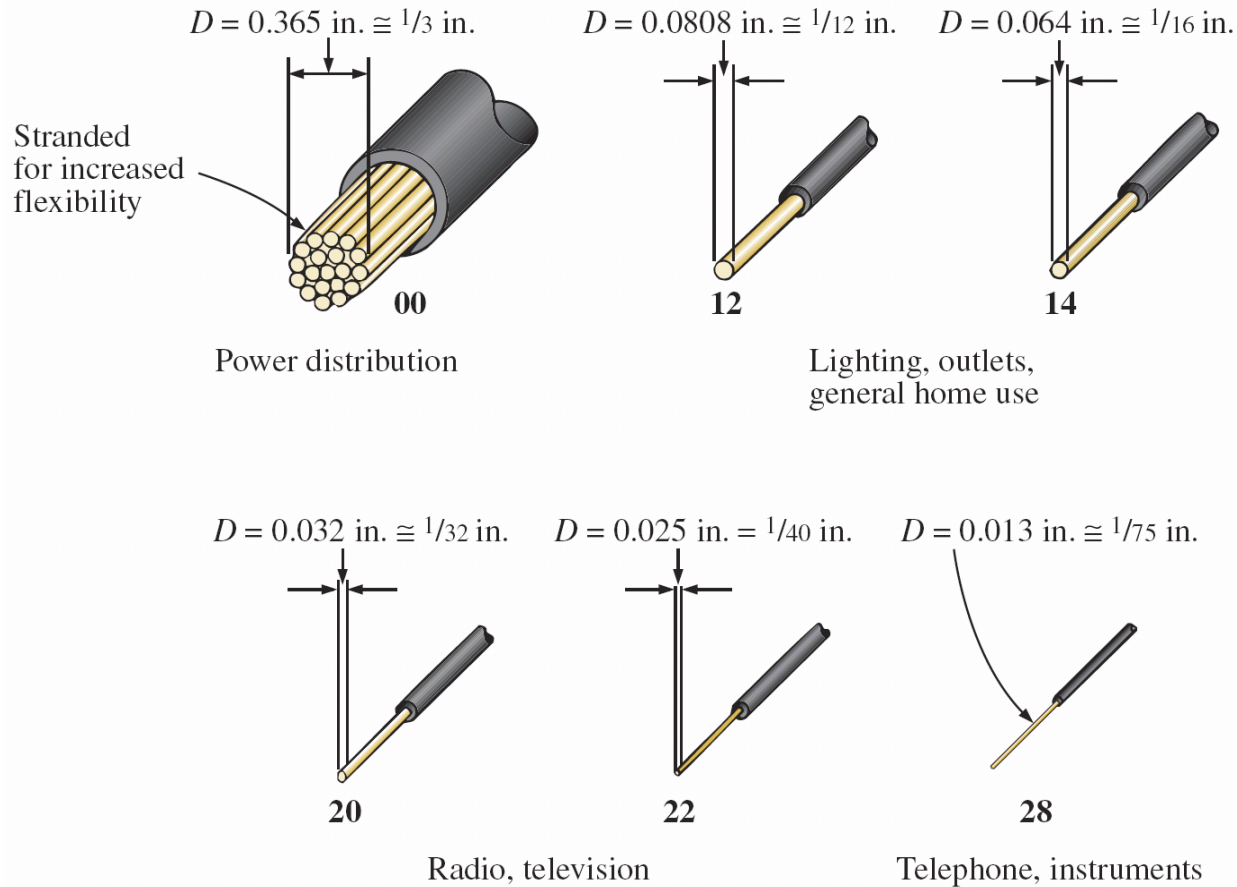

FIG. 3.8 Popular wire sizes and some of their areas of application.



TYPES OF RESISTORS

Fixed Resistors

- ❖ Resistors are made in many forms, but all belong in either of two groups: fixed or variable.
- ❖ The most common of the low-wattage, fixed type resistors is the film resistor.





TYPES OF RESISTORS

Fixed Resistors

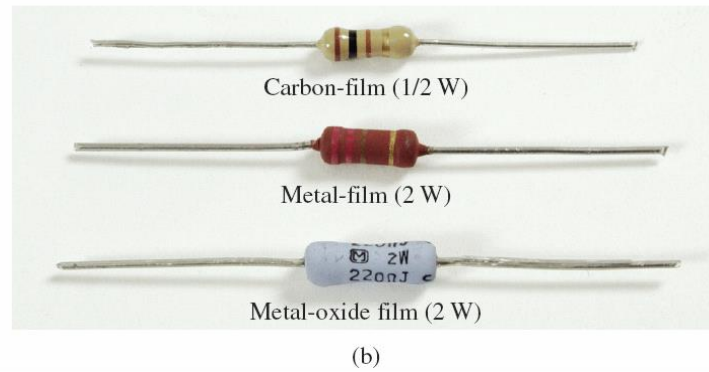
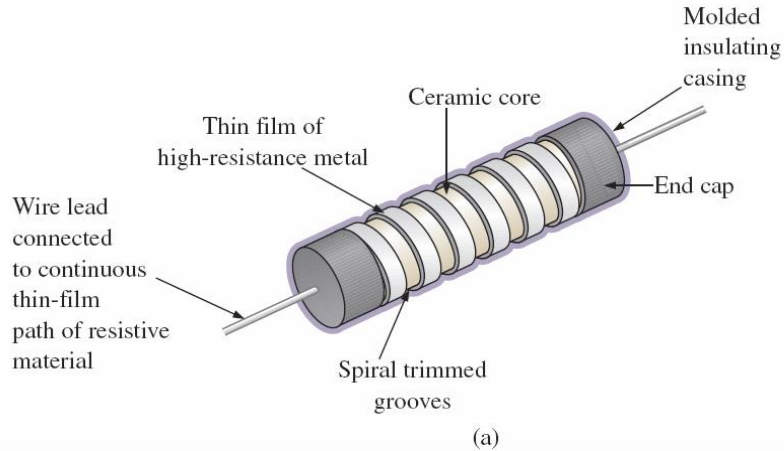

FIG. 3.12 Film resistors: (a) construction; (b) types.



TYPES OF RESISTORS

Fixed Resistors

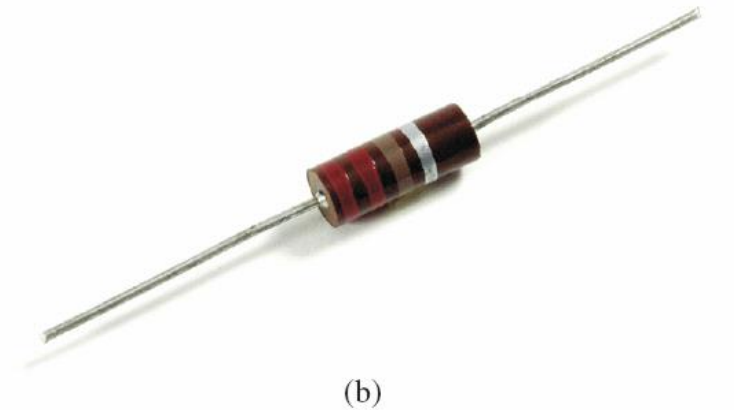
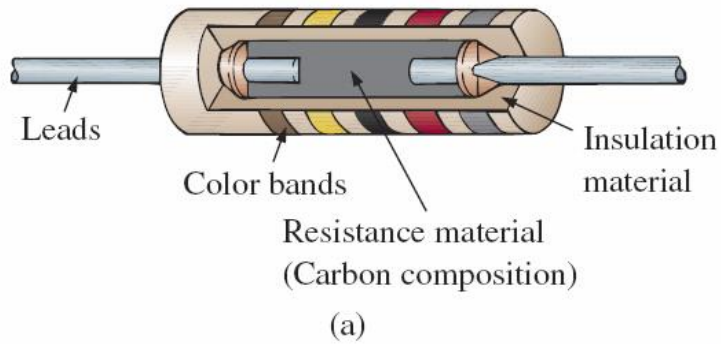

FIG. 3.13 Fixed-composition resistors: (a) construction; (b) appearance.





TYPES OF RESISTORS

Fixed Resistors



ACTUAL SIZE

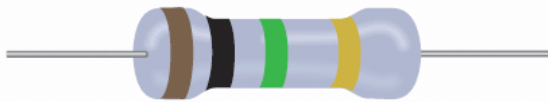

5 W

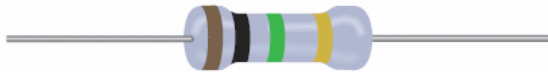

3 W



1 W



$\frac{1}{2}$ W



$\frac{1}{4}$ W

FIG. 3.14 *Fixed metal-oxide resistors of different wattage ratings.*



TYPES OF RESISTORS

Fixed Resistors



100 Ω , 25 W
2 k Ω , 8 W

470 Ω , 35 W
Thick-film power resistor
(b)

1 k Ω , 25 W
Aluminum-housed, chassis-mount resistor-precision wire-mount
(c)

100 M Ω , 0.75 W
Precision power film resistor
(d)

25 k Ω , 5 W
Silicon-coated, wire-wound resistor
(g)

Wire-wound resistors
(a)

1 k Ω bussed (all connected on one side) single in-line resistor network
(e)

22 k Ω , 1 W
Surface mount thick-film chip resistors with gold electrodes
(f)

Labels in (a): Tinned alloy terminals, Vitreous enamel coating, Even uniform winding, High-strength welded terminal, Resilient mounting brackets, Strong ceramic core, Welded resistance wire junction.

Labels in (b): Resistive material, Bakelite (insulator) coating, Terminals.

Labels in (c): Electrodes (Terminals), Ceramic base, Resistive material.

FIG. 3.15 Various types of fixed resistors.



TYPES OF RESISTORS

Variable Resistors

- ❖ Variable resistors, as the name implies, have a terminal resistance that can be varied by turning a dial, knob, screw, or whatever seems appropriate for the application.
- ❖ They can have two or three terminals, but most have three terminals. If the two- or three-terminal device is used as a variable resistor, it is usually referred to as a **rheostat**.





TYPES OF RESISTORS

Variable Resistors

- ❖ If the three-terminal device is used for controlling potential levels, it is then commonly called a **potentiometer**.
- ❖ Even though a three-terminal device can be used as a rheostat or a potentiometer (depending on how it is connected), it is typically called a *potentiometer* when listed in trade magazines or requested for a particular application.





TYPES OF RESISTORS

Variable Resistors

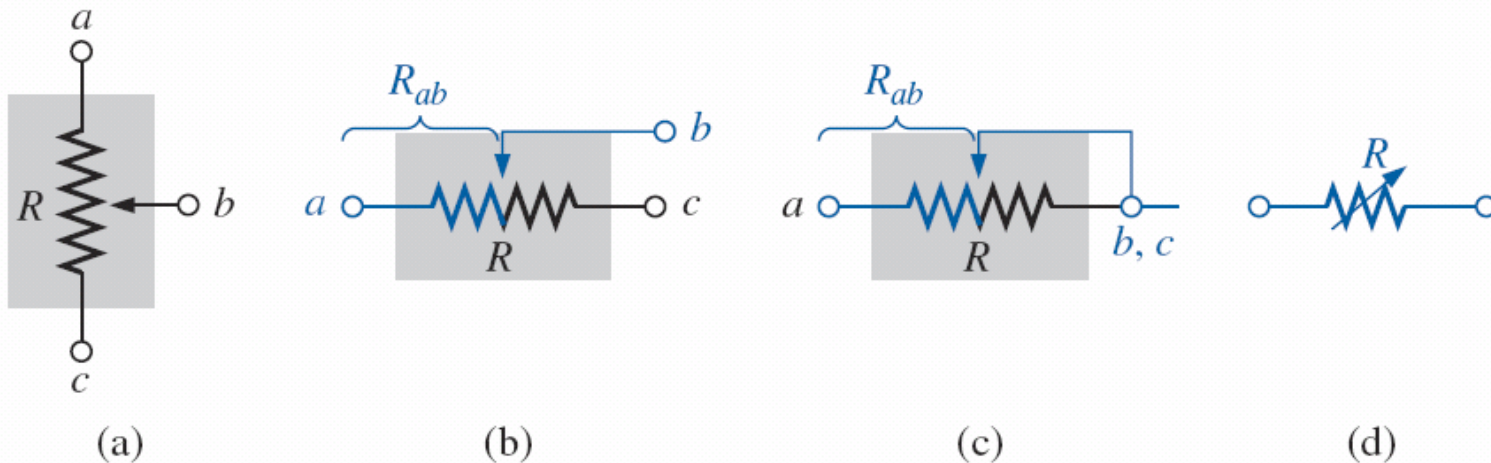

FIG. 3.16 Potentiometer: (a) symbol; (b) and (c) rheostat connections; (d) rheostat symbol.





TYPES OF RESISTORS

Variable Resistors

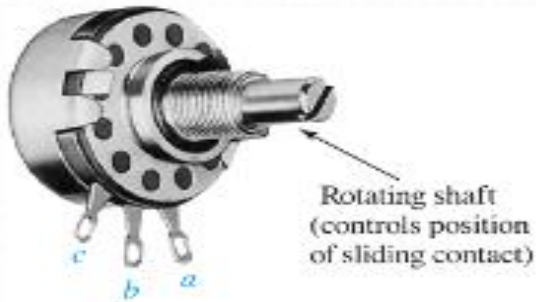

(a) External view

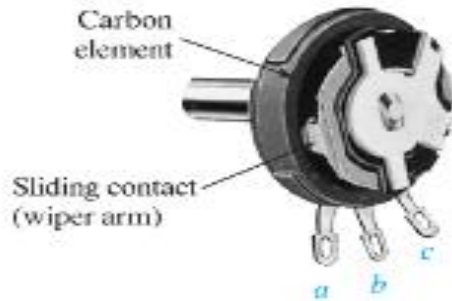

(b) Internal view

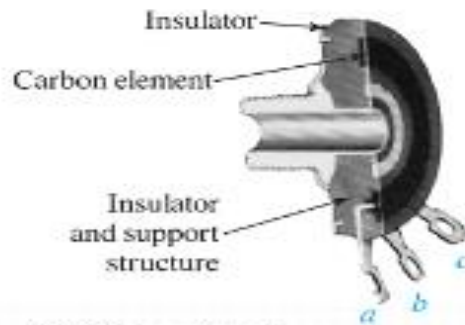

(c) Carbon element



FIG. 3.17 *Molded composition-type potentiometer.*
(Courtesy of Allen-Bradley Co.)



TYPES OF RESISTORS

Variable Resistors

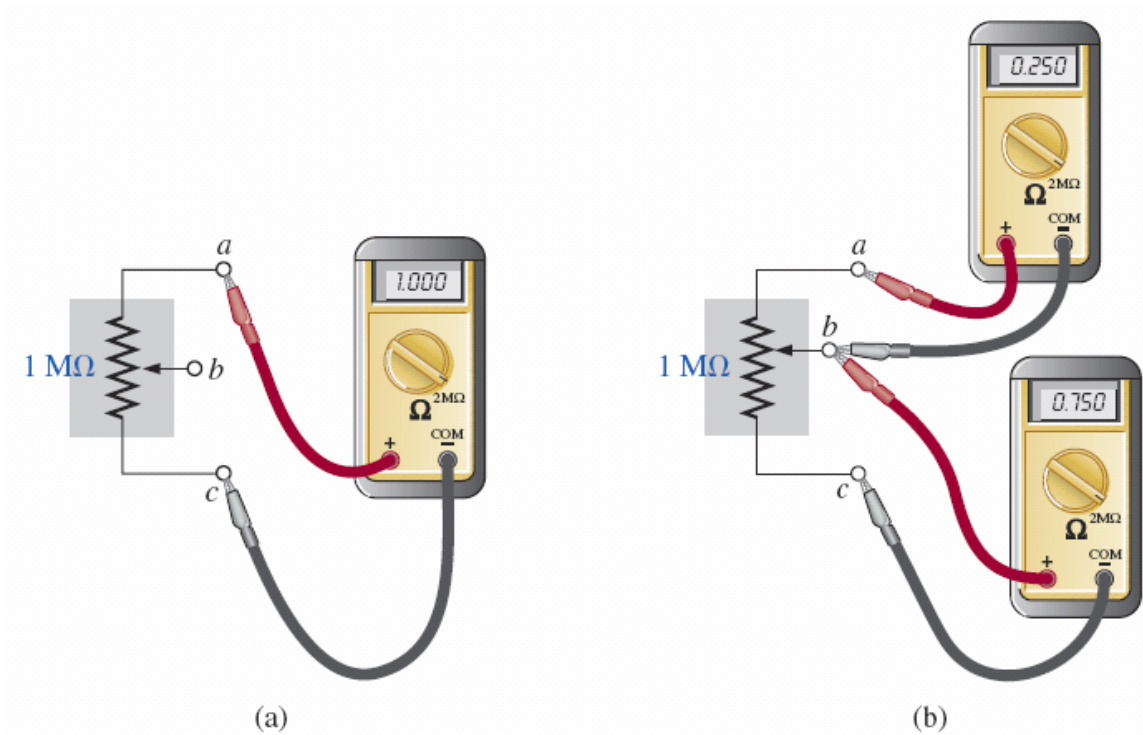
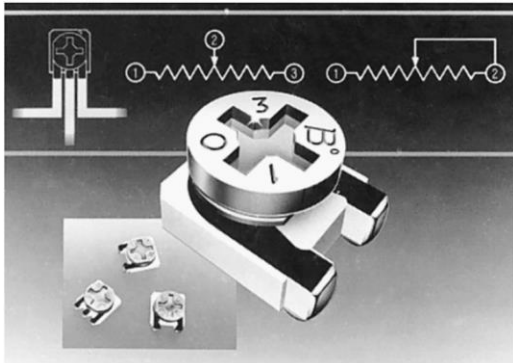

FIG. 3.18 Resistance components of a potentiometer: (a) between outside terminals; (b) between wiper arm and each outside terminal.



TYPES OF RESISTORS

Variable Resistors



(a)

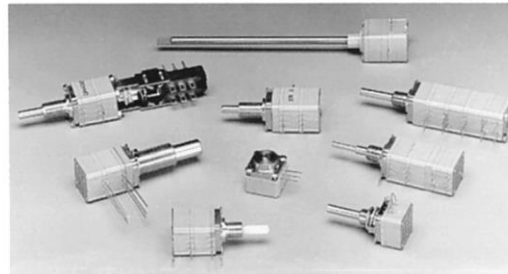

(b)



(c)

FIG. 3.19 Variable resistors: (a) 4 mm (5/32 in.) trimmer (courtesy of Bourns, Inc.); (b) conductive plastic and cermet elements (courtesy of Honeywell Clarostat); (c) three-point wire-wound resistor.



COLOR CODING AND STANDARD RESISTOR

VALUES

- ❖ A wide variety of resistors, fixed or variable, are large enough to have their resistance in ohms printed on the casing.
- ❖ Some, however, are too small to have numbers printed on them, so a system of **color coding** is used.
- ❖ For the thin-film resistor, four, five, or six bands may be used.
- ❖ The four-band scheme is described.
- ❖ Later in this section the purpose of the fifth and sixth bands will be described.





COLOR CODING AND STANDARD RESISTOR VALUES

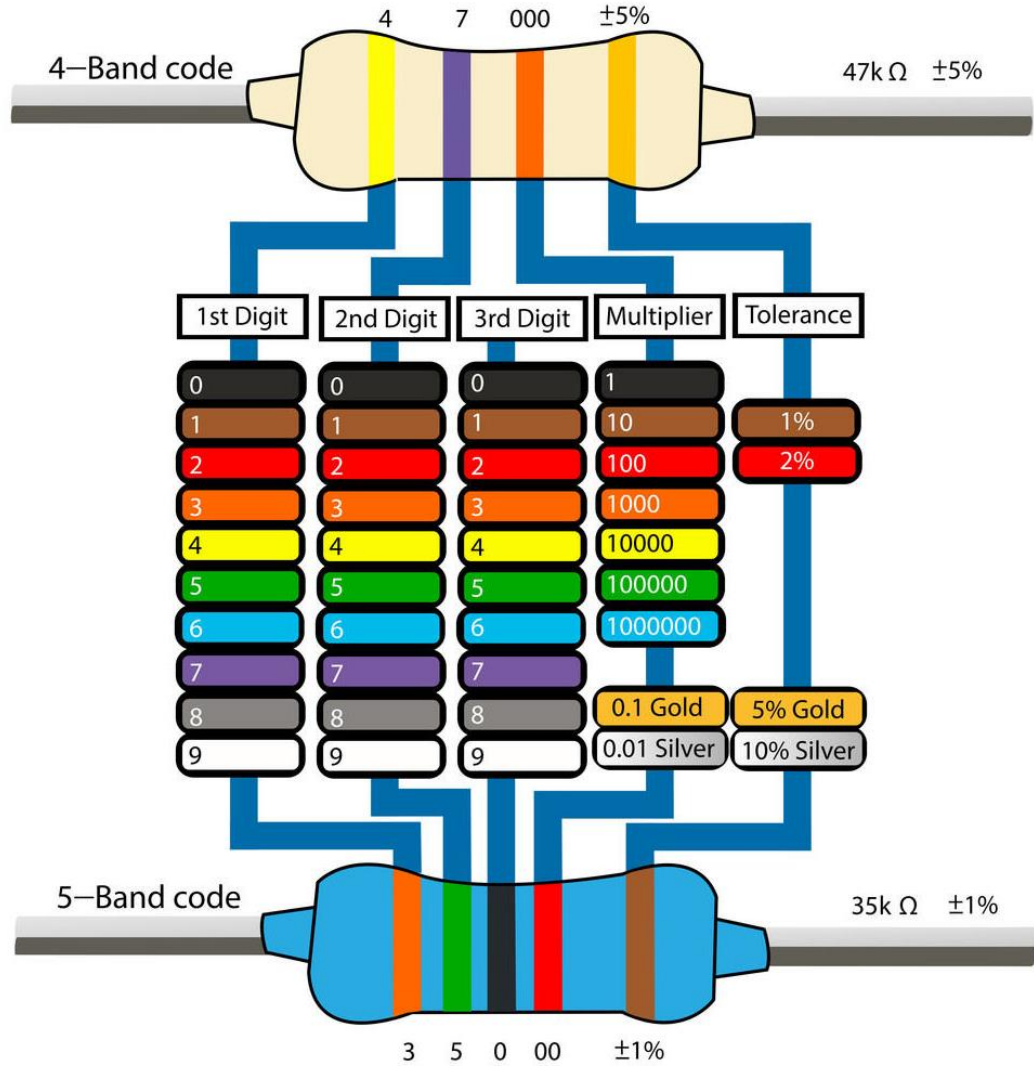



COLOR CODING AND STANDARD RESISTOR VALUES



Ohms (Ω)					Kilohms ($k\Omega$)		Megohms ($M\Omega$)	
0.10	1.0	10	100	1000	10	100	1.0	10.0
0.11	1.1	11	110	1100	11	110	1.1	11.0
0.12	1.2	12	120	1200	12	120	1.2	12.0
0.13	1.3	13	130	1300	13	130	1.3	13.0
0.15	1.5	15	150	1500	15	150	1.5	15.0
0.16	1.6	16	160	1600	16	160	1.6	16.0
0.18	1.8	18	180	1800	18	180	1.8	18.0
0.20	2.0	20	200	2000	20	200	2.0	20.0
0.22	2.2	22	220	2200	22	220	2.2	22.0
0.24	2.4	24	240	2400	24	240	2.4	
0.27	2.7	27	270	2700	27	270	2.7	
0.30	3.0	30	300	3000	30	300	3.0	
0.33	3.3	33	330	3300	33	330	3.3	
0.36	3.6	36	360	3600	36	360	3.6	
0.39	3.9	39	390	3900	39	390	3.9	
0.43	4.3	43	430	4300	43	430	4.3	
0.47	4.7	47	470	4700	47	470	4.7	
0.51	5.1	51	510	5100	51	510	5.1	
0.56	5.6	56	560	5600	56	560	5.6	
0.62	6.2	62	620	6200	62	620	6.2	
0.68	6.8	68	680	6800	68	680	6.8	
0.75	7.5	75	750	7500	75	750	7.5	
0.82	8.2	82	820	8200	82	820	8.2	
0.91	9.1	91	910	9100	91	910	9.1	

TABLE 3.5 *Standard values of commercially available resistors.*



OHMMETERS

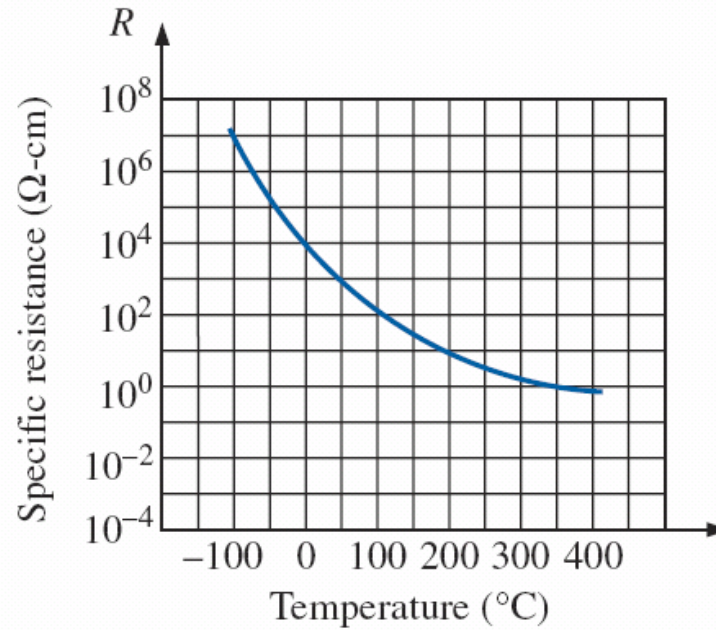

FIG. 3.30 *Identifying the leads of a multilead cable.*



THERMISTORS

❖ The **thermistor** is a two-terminal semiconductor device whose resistance, as the name suggests, is temperature sensitive.



(a)

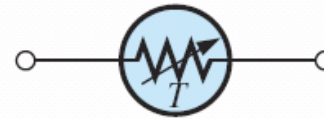

(b)

FIG. 3.36 Thermistor: (a) characteristics; (b) symbol.





THERMISTORS

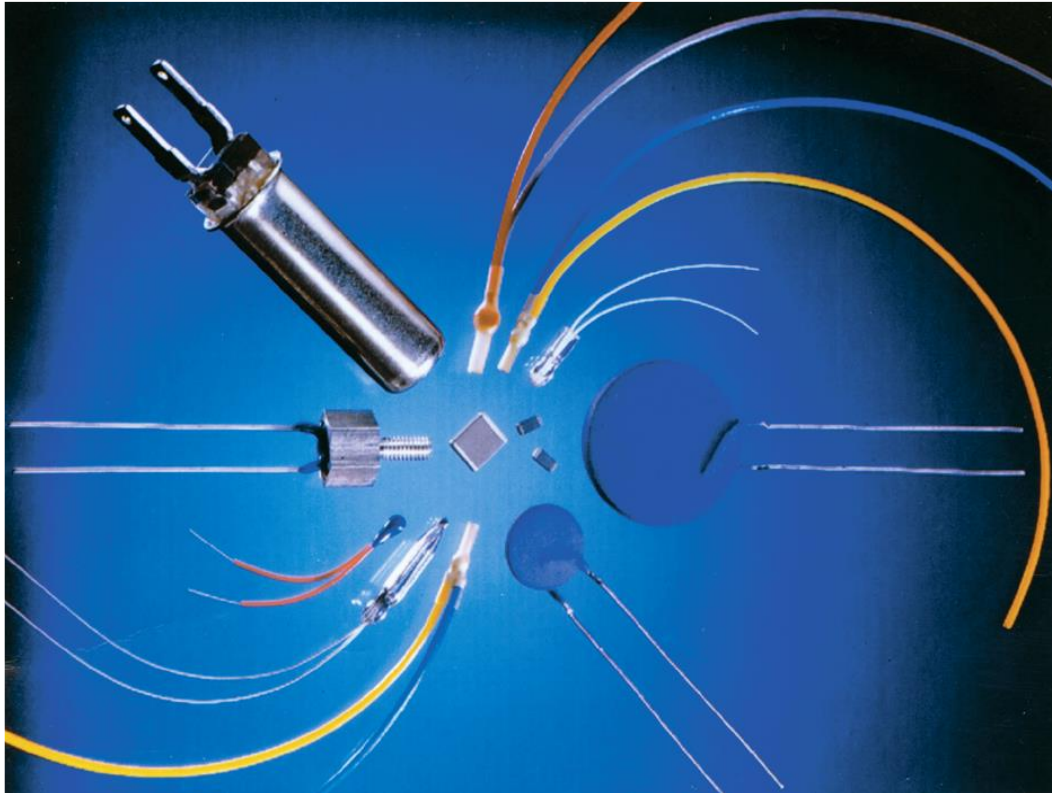

FIG. 3.37 *NTC (negative temperature coefficient) and PTC (positive temperature coefficient) thermistors.*





PHOTOCONDUCTIVE CELL

- ❖ The **photoconductive cell** is a two-terminal semiconductor device whose terminal resistance is determined by the intensity of the incident light on its exposed surface.
- ❖ As the applied illumination increases in intensity, the energy state of the surface electrons and atoms increases, with a resultant increase in the number of “free carriers” and a corresponding drop in resistance.

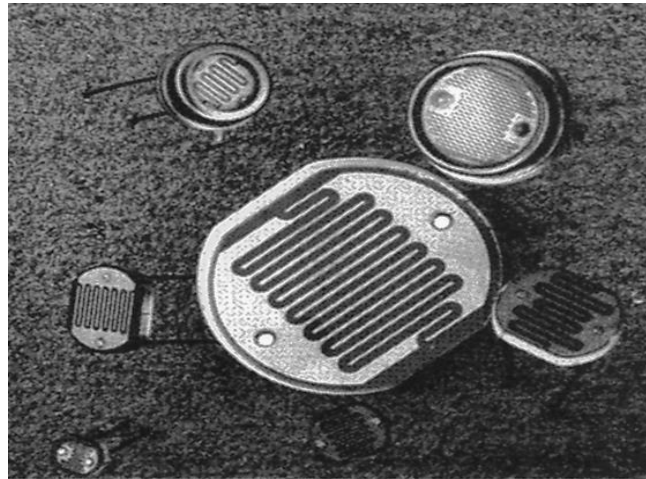
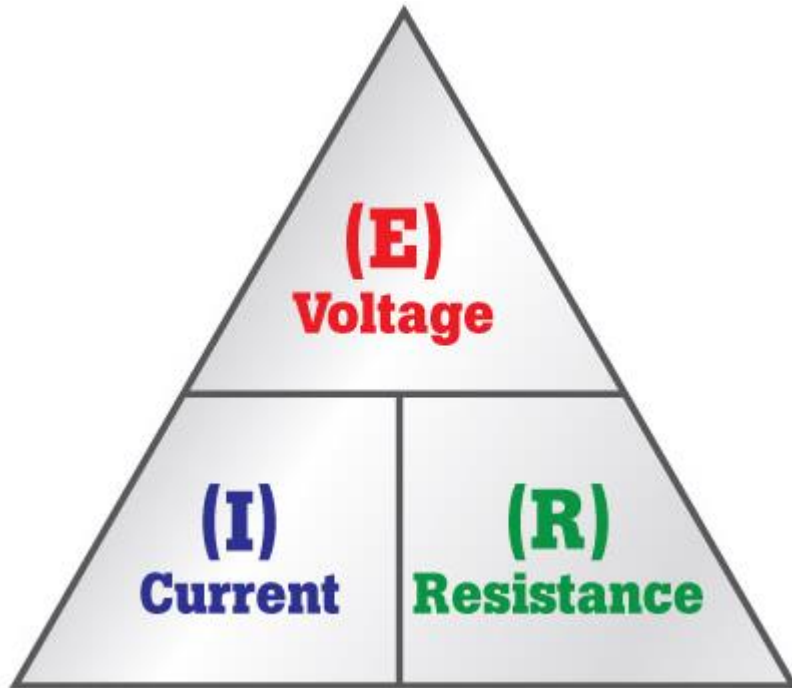

FIG. 3.39
Photoconductive cells.



OHM'S LAW



$$I = \frac{E}{R}$$

(amperes, A)

$$E = IR$$

(volts, V)

$$R = \frac{E}{I}$$

(ohms, Ω)



OHM'S LAW

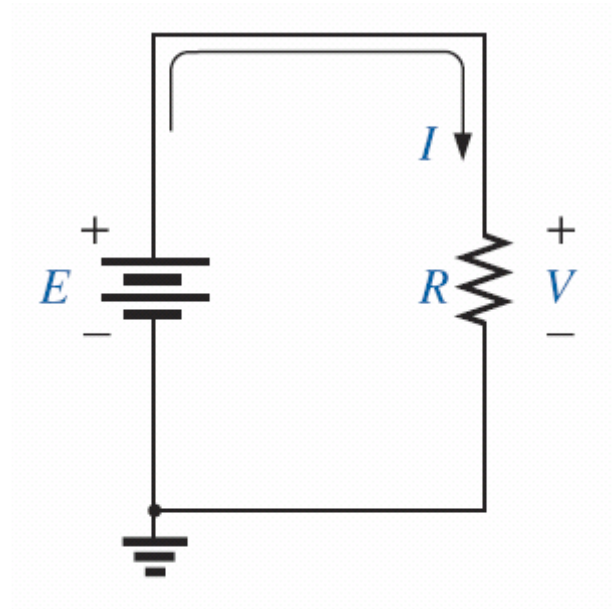

FIG. 4.2 *Basic circuit.*



OHM'S LAW



$$I = \frac{V_R}{R} = \frac{E}{R}$$

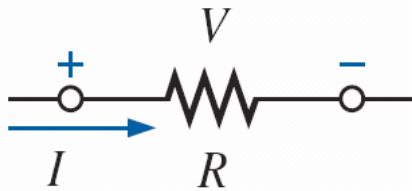

(a)

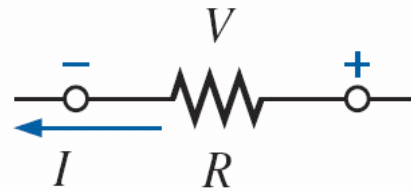

(b)

FIG. 4.3 *Defining polarities.*



PLOTTING OHM'S LAW

- ❖ Graphs, characteristics, plots, and the like play an important role in every technical field as modes through which the broad picture of the behavior or response of a system can be conveniently displayed.
- ❖ It is therefore critical to develop the skills necessary both to read data and to plot them in such a manner that they can be interpreted easily.





PLOTTING OHM'S LAW

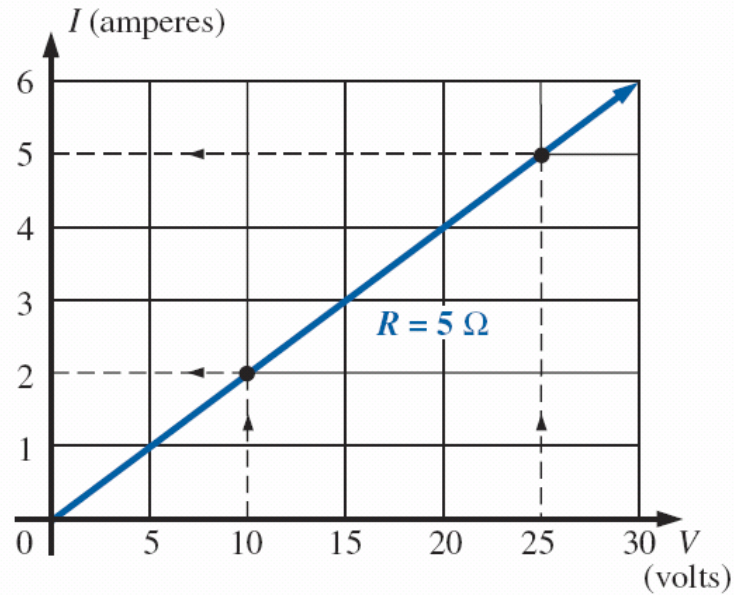
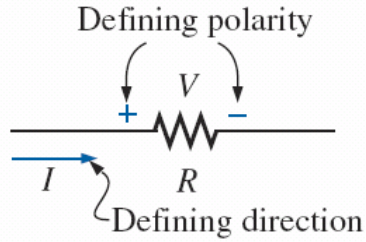

FIG. 4.6 Plotting Ohm's law.



PLOTTING OHM'S LAW

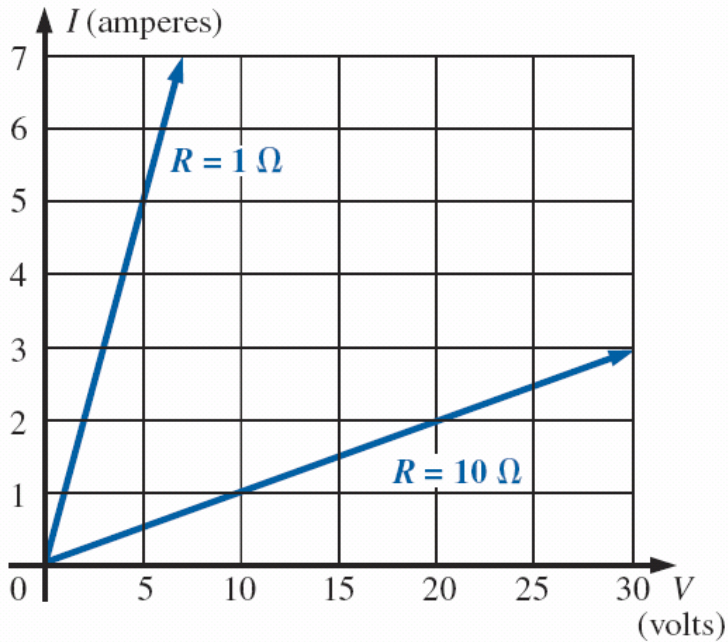

FIG. 4.7 Demonstrating on an I - V plot that the lower the resistance, the steeper is the slope.



POWER

- ❖ In general, *the term power is applied to provide an indication of how much work (energy conversion) can be accomplished in a specified amount of time; that is, power is a rate of doing work.*





ENERGY



$$\text{Energy (Wh)} = \text{power (W)} \times \text{time (h)}$$

$$\text{Energy (kWh)} = \frac{\text{power (W)} \times \text{time (h)}}{1000}$$



ENERGY

- ❖ Note that the energy in kilowatthours is simply the energy in watthours divided by 1000.
- ❖ To develop some sense for the kilowatthour energy level, consider that *1 kWh is the energy dissipated by a 100 W bulb in 10 h.*
- ❖ The **kilowatthour meter** is an instrument for measuring the energy supplied to the residential or commercial user of electricity.





ENERGY

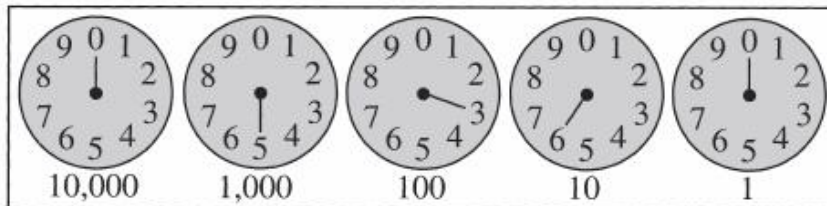

(a)



(b)

FIG. 4.16 Kilowatt-hour meters: (a) analog; (b) digital. (Courtesy of ABB Electric Metering Systems.)



ENERGY

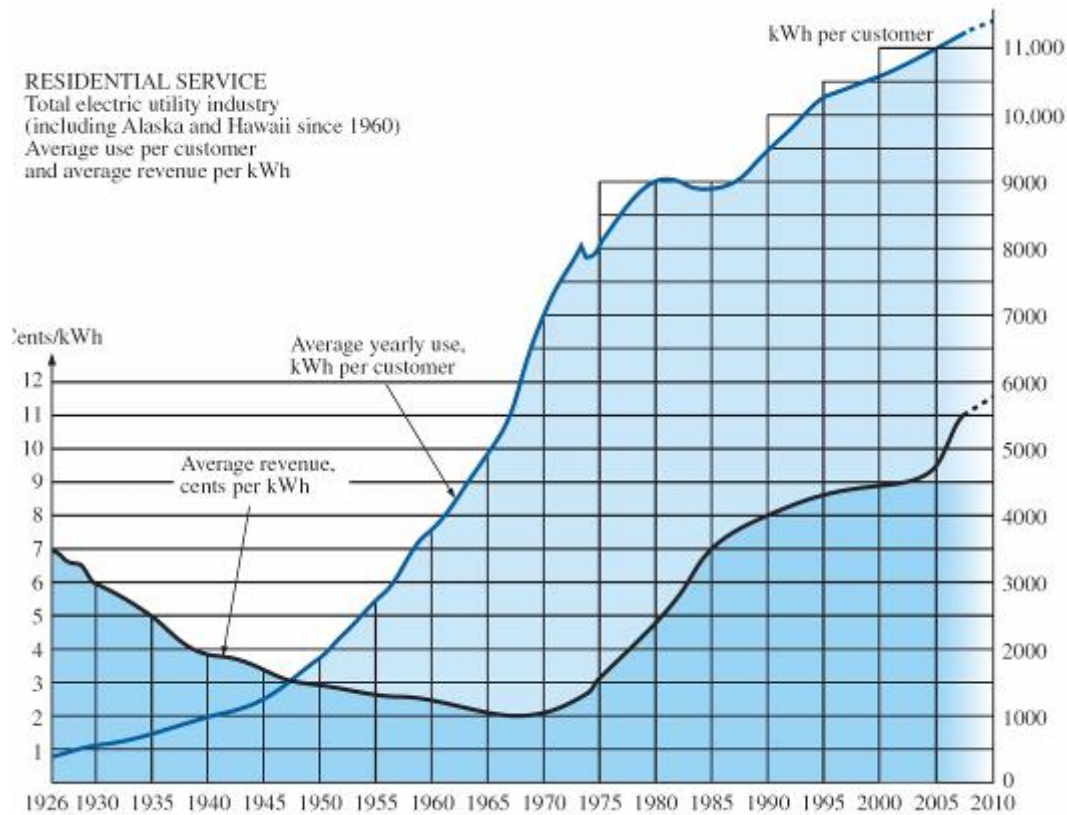

FIG. 4.17 Cost per kWh and average kWh per customer versus time. (Based on data from Edison Electric Institute.)



ENERGY



Appliance	Wattage Rating	Appliance	Wattage Rating
Air conditioner (room)	1400	Laptop computer: Sleep	< 1 (typically 0.3 to 0.5)
Blow dryer	1300	Average use	78
Cellular phone: Standby	$\cong 35$ mW	Microwave oven	1200
Talk	$\cong 4.3$ W	Nintendo Wii	19
Clock	2	Radio	70
Clothes dryer (electric)	4300	Range (self-cleaning)	12,200
Coffee maker	900	Refrigerator (automatic defrost)	1800
Dishwasher	1200	Shaver	15
Fan: Portable	90	Sun lamp	280
Window	200	Toaster	1200
Heater	1500	Trash compactor	400
Heating equipment: Furnace fan	320	TV: Plasma	340
Oil-burner motor	230	LCD	220
Iron, dry or steam	1000	VCR/DVD	25
		Washing machine	500
		Water heater	4500
		Xbox 360	187

TABLE 4.1 Typical wattage ratings of some common household items.

Thank You !

